

MUSÉE  
UNTER  
LINDEN

**Le nouvel  
Unterlinden**  
Bienvenue  
à Colmar

[musee-unterlinden.com](http://musee-unterlinden.com)



Crédit: Musée Centre Est Europe, Timken Foundation, M. Thomas Dietschweiler, M. et M<sup>me</sup> William et Judith Scheide

**Press kit**

# The Museum Expansion

The Musée Unterlinden's new dimension at the heart of the Rhine region and its architecture, with the juxtaposition of the cloister inviting contemplation and helical staircases symbolising movement, should not eclipse the definition of a museum.

Its walls display artworks in greater numbers than ever before. In front of these works, visitors are educated, amazed, intrigued, delighted; they exchange opinions... in short, they come alive.

## Map of the Musée Unterlinden

- |                   |             |
|-------------------|-------------|
| 1. Entrance, Exit | 5. Gallery  |
| 2. Cloister       | 6. Ackerhof |
| 3. Chapel         | 7. Piscine  |
| 4. House          | 8. Cour     |

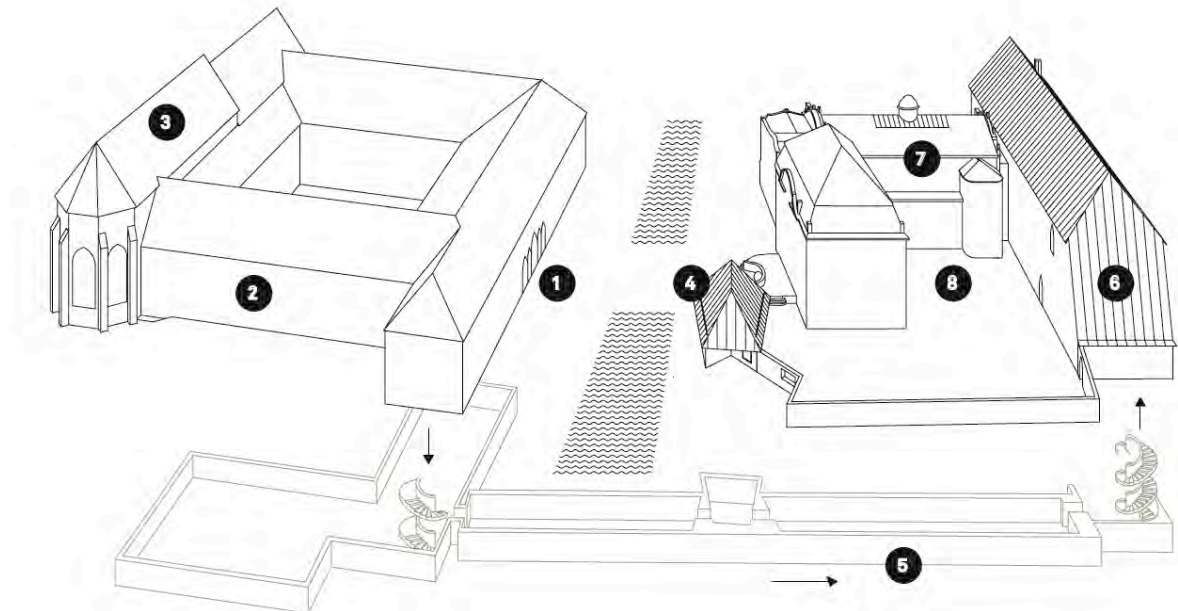

# Urbanism, architecture and museography

---

## Museum expansion in Colmar 2012-2015

The project for the extension of the Unterlinden Museum in Colmar encompasses three dimensions: urban development, architecture and museography. It centers on the issues of reconstruction, simulation and integration.

### Urban development

After the extension, two building complexes face each other across the Unterlinden square, whilst they are physically connected by an underground gallery. The medieval convent consisting of a church, a cloister, a fountain and a garden stand to one side. On the other side of the square, the new museum building mirrors the church's volume and, together with the former municipal baths constitutes a second, enclosed court.

Between the two museum complexes, the Unterlinden Square has recovered its historical significance, recalling the times when stables and farm buildings formed across from the convent, an ensemble called "Ackerhof". What was before the museum's renovation a bus stop and a parking lot, has become a new public and urban space. The Sinn canal, which flows under Colmar's old town, is reopened and becomes the central element of this new public space. Close to the water, a small house marks the museum's presence on the square: its positioning, volume and shape are those of the mill that once stood there. Two windows allow passers-by to look downwards at the underground gallery connecting the two ensembles of buildings.

### Architecture

We were looking for an urban configuration and architectural language that would fit into the old town and yet, upon closer inspection, appear contemporary.

Moved to the centre of the Unterlinden square, facing the canal, the entrance to the expanded Museum leads to the convent, whose facade was delicately renovated. The renovation works were carried out in close collaboration with the architects of the French national heritage. Museological components from the recent past were removed and the spaces restored to a former state. We revealed original wood ceilings and reopened formerly blocked windows looking out on the cloister and the city. The church's roof was renovated and a new wood floor was installed in the nave. Visitors walk down a new, cast spiral staircase leading to the underground gallery that connects the convent with the new building.

Inside, we decided to design the underground gallery and the new exhibition building (now called "Ackerhof"), which present the 19th- and 20th-century collections, along contemporary, abstract lines. The space on the second floor of the Ackerhof is dedicated to temporary exhibitions: its gabled roof and exceptional height (11.5 meters) reflect the proportions/volumes of the Dominican church standing opposite. The central space of the former municipal baths, the swimming pool ("La Piscine"), is connected to the new exhibition spaces. It serves as a venue for concerts, conferences, celebrations and contemporary art installations. The other spaces of the former baths house the administration of the museum, a library, a café facing the new courtyard and the Colmar Tourist Office facing Unterlinden Square.

The Ackerhof and the small house have facades made of irregular, hand-broken bricks, entering into dialogue with the convent facades in quarry stone and plaster that were redone many times over the centuries. A few lancet windows are cut into these brick walls; the roof

gables are in copper. The new courtyard is paved in sandstone, as is the Unterlinden Square, while the enclosing walls are made of the same brick as the new buildings. At the heart of the courtyard, an orchard, the “Pomarium” is growing on a platform made of stone and brick.

### **Collection and Museography**

In close collaboration with Jean-François Chevrier and Élia Pijollet, as well as with the museum’s curators, the museography and the architecture go hand in hand. The collections comprise works of worldwide renown from the Middle Ages and the Renaissance—most notably, the Isenheim Altarpiece by Matthias Grünewald and Nicolas von Hagenau (1505-1516, but also designs, prints and patterns for the production of textiles, photographs, paintings, sculptures, faience pieces and ethnographic objects from the 19th and early 20th centuries, with a focus on local art and art history. From the 1960s onwards, a modern art collection was built up. As to the Isenheim Altarpiece, it remains in its original if more light-filled and less cluttered convent church location, although its presentation frame has been replaced by a sober steel structure. This makes the painted wood panels look more like artworks. Eleventh- to sixteenth-century paintings, sculptures, small altars and artifacts are on display on the neighboring ground floor and in the cloister. The downstairs floor presents the archaeological collections. The underground gallery consists of a succession of three very different exhibition

spaces. Beginning the circuit, we have the history of the Unterlinden Museum, covering a section of 19th-century and early 20th-century works. The second gallery displays three of the Museum’s most important pieces: located under the little house, this room represents the core of the expanded Unterlinden Museum, uniting the project’s three dimensions: urban development, architecture and museography.

On the first and second floors, the new building represents a loose chronological sequence of the 20th-century collection. Interconnected spatial units organize and structure the floor’s overall volume, rather than subdividing it: here works or groups of works are exhibited in relation to one another.

Together with the museography for the collection of 20th-century art, the inaugural exhibition (from January to June 2016), curated by Jean-François Chevrier, will serve as an outstanding example of the uses to which the newly acquired spaces can be put, while presenting an exemplary reading of specific pieces from the collection.

### **Herzog & de Meuron, December 2015**

# Presentation

## The Musée Unterlinden (1853 – 2015)

---

Designed by Herzog & de Meuron, the Musée Unterlinden's new extension aims to perfectly integrate its contemporary architecture into the centuriesold history of the building and its collections. It is the result of a thorough going, ambitious plan for the future role of the museum and its position in the Rhine Valley, at the centre of a network of leading cultural institutions.

As at the creation of the museum in 1853, the early 2000s witnessed the convergence of several decisive factors. The museum's different strata had lost their original coherence over the years, while the contrast with new recently created cultural structures highlighted the obsolescence of the infrastructure.

At the same time, moreover, the collections of modern art were significantly enriched as the result of the effective acquisitions policy conducted by the curators with the support of the Société Schongauer, combined with a number of important donations. In 2008 the Parisian collector Jean-Paul Person bequeathed nearly a hundred and fifty works, a number of them illustrating the French art scene in the mid-twentieth century, with artists like Victor Brauner, Germaine Richier, Nicolas de Staël and Gaston Chaissac. This ensemble featured thirty-five works by Jean Dubuffet covering the full range of the artist's work, but especially the *Hourloupe* period between 1962 and 1974.

In 2009 Emmanuel Wardi donated a highly representative ensemble of works by Joe Downing, an American artist who settled in France after the Second World War and belonged to the Lyrical Abstraction movement of the 1950s. Sculptures by Simone Boisecq and Karl-Jean Longuet featured among other additions to the museum's modern art collection, which previously had few three-dimensional works.

Created in the basement area in the 1970s, the modern art spaces soon proved too modest. There was also a clear need for dedicated temporary exhibition spaces, so plans were made for a second underground extension.

However, the situation and possibilities changed significantly when the municipal baths closed and the city council allocated the building to the museum.

Built opposite the museum in 1906, during the period of annexation, the baths were part of Germany's public hygiene programme, which also saw the construction of municipal baths in Strasbourg in 1908 and Mulhouse three years later. In Colmar, the architect Ulysse Bertsch designed a neobaroque façade and created highly refined interiors. With offices and reception spaces housed in the main structure, his building was conceived to house two pools, only one of which was completed. Hence its L-shaped structure.

The allocation of the baths allowed the museum to plan a much more ambitious extension and to completely redeploy the collections.

An international architecture competition was organised in 2009, and the project was awarded to the Basel-based firm Herzog & de Meuron.

This involved much more than the simple addition of a new wing.

Founded in 1978, the architectural practice of Jacques Herzog and Pierre de Meuron has become internationally renowned for its public and private buildings and urban development projects, its position confirmed by the Pritzker Prize in 2001. Past achievements include the Tate Modern conversion in London (2000) and the construction of the Schaulager in Basel (2003), the Caixa Forum in Madrid (2003–2008) and the Olympic Stadium in Beijing (2008).

For the Musée Unterlinden, Herzog & de Meuron came up with a simultaneously architectural and museographic project which also expresses the building's urban role. Their design eschews architectural gesticulation and integrates smoothly into the historical strata of a city centre with a strong architectural identity. The central idea, guided by respect for the medieval convent, was to link this to a modern wing attached to the municipal baths by an underground gallery.

An aerial view gives an idea of the underlying

constructive logic. Having identified the iconic elements of the convent, such as the cloister garden and the chapel, the architects evoked these with a symmetrical structure behind the baths, thereby creating a new architectural entity: the form of the chapel is echoed by the bulk of the modern wing, at the foot of which a newly created garden recalls the cloister. A similar approach governed the choice of materials: the new wing, with its copper pitched roof and raking gable, is clad with bricks, split lengthwise, in an intelligent echo of the colour and roughness of the chapel walls.

The project by Herzog & de Meuron also has an urban dimension, in that it aims to integrate the space between the baths and the convent, where the museum entrance will now be, into the life of the city, its attractiveness increased by the reopening of the Sinn Canal and the new landscaping of its banks. This space features a small house clad in the same materials as the modern wing. With large bay windows giving onto the underground gallery running past below, linking the convent to the bath house, it plays an essential, pivotal role in the conception of the site and serves to signal the underground articulation of the buildings. The forms of this small structure reprise those of the building (Moulin Weck) marking the entrance of the Ackerhof, as known from old photographs, providing another illustration of Herzog & de Meuron's interest in the traces left by history on the site.

The other aspect of the project is the reorganisation of the museum, designed to restore coherence to the collections by showing pre-modern art in the convent and modern art in the new wing, while doubling the museum's exhibition space.

Organisation of the convent rooms is no longer

thematic but chronological, allowing visitors to compare different aspects of the art of a given period. The gallery linking the old building to the modern wing, divided into three zones, opens with an evocation of the history of the building and museum. At the centre of the gallery, the naturally lit space located below the little house is conceived as an architectural and symbolic articulation. Only three works are exhibited here, and stand as a synthesis of the museum's history: *The Chariot of Death* by Théophile Schuler illustrates history and the past, while *Christ among the Doctors* by Rouault evokes the strong religious dimension of the collections and *The Valley of the Creuse* by Claude Monet represents the opening to modern art. Featuring three small rooms dedicated to prints and drawings, the last section of the gallery covers the art of the nineteenth and early twentieth centuries. In the new wing, two exhibition levels are dedicated to the collections of modern art, displayed according to the innovative "floating picture wall" principle, while the space under the pitched roof is used for temporary exhibitions. The three floors are linked by an understated and contemporary spiral staircase in concrete. Inspired by the arches in the cloister, the openings of the modern wing offer a contemporary take on the Gothic arch. The temporary exhibitions room gives access to the pool area of the former municipal baths which, under its glass roof, serves as an events space. To assert its historical roots while looking boldly to the future – that is the ambition of the new Musée Unterlinden as regenerated by Herzog & de Meuron's architectural proposition. It has all the resources it needs to establish its position among leading museums and to pursue a bold and attractive exhibitions policy designed for all kinds of visitors. Putting the bric-a-brac evoked by Huysmans over a century ago well behind it, the Musée Unterlinden is entering a new phase in its history.



# The collections

---

A visit to the Musée Unterlinden covers nearly 7,000 years of history, from the prehistoric era to 20th century art.

Whilst travelling in time amidst the museum's encyclopaedic collections, visitors can also discover the multiple facets of its architecture, which have been unified and enhanced by the architects Herzog & de Meuron.

The Medieval cloister presents the art of the Middle Ages and the Renaissance, with works by the likes of Martin Schongauer, Hans Holbein and Lucas Cranach, as well as the museum's great masterpiece, the *Isenheim Altarpiece* (1512–1516) by Grünewald and Niclaus of Hagenau. The former baths building inaugurated in

1906 provides a perfect space for temporary events, whilst the works of major 20th century artists such as Monet, de Staël, Picasso and Dubuffet have a new showcase in the contemporary wing.

**Cloister  
Entrance**

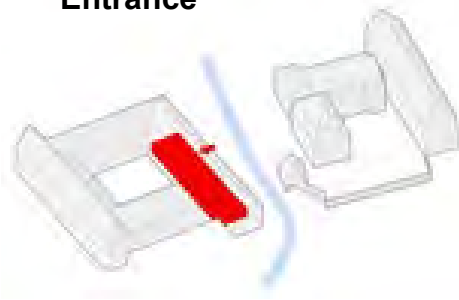

*Nouvelle entrée du Musée Unterlinden* © Herzog & de Meuron

# Cloister

## Art of Middle Ages and the Renaissance

### Arts 11e – 16e century

The museum's permanent collections of medieval and Renaissance art offer visitors the opportunity to explore the multiple facets of Germanic art in depth, including painted panels, sculptures, tapestries, silver and gold pieces, stained-glass windows, etc.

Masterpieces as the *Melancholy* (1532) by Lucas Cranach the Elder and the *Portrait of a Woman* (c. 1510) by Hans Holbein the Elder, illustrate the ways in which human beings and their perceptions of the world around them became central in the art of this period.

### Cloister

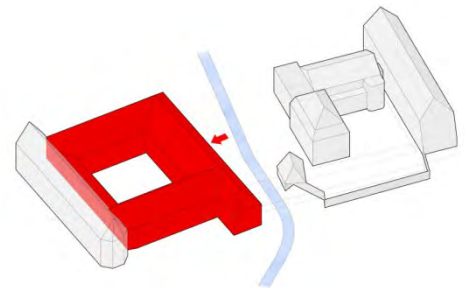

**Peintre strasbourgeois, Hermann Schadeberg ?**  
*La Crucifixion*, entre 1410 et 1415, huile sur bois (sapin), Musée Unterlinden, Colmar



## Martin Schongauer (Colmar, c. 1445- Breisach, 1491)

Martin Schongauer, also known as “Martin the beautiful”, was one of the greatest engravers and painters of the Upper Rhine in the late 15<sup>th</sup> century. Paradoxically, the lack of archive sources and written accounts has made it difficult to reconstruct his life, and in particular his training as an artist.

He was born in Colmar in around 1445 to a family originating from Schongau, in southern Bavaria. His father Caspar was a goldsmith, who settled in Colmar in May 1440. Of his five sons, Jörg, Caspar the younger and Paul followed in their father’s footsteps and became goldsmiths, whilst Ludwig and Martin chose to become painters. In around 1460, the young Martin received a solid grounding in his father’s workshop, where the rigour and precision of the goldsmith’s trade would have a major influence on his future mastery of burin engraving. He then began his apprenticeship as a painter, before leaving in October 1465 for the University of Leipzig. On the way, he stopped in Nuremberg, where he frequented the studio of Hans Pleydenwuff (active between 1457 and

1472). There he came into contact with models strongly influenced by the masters of Flemish art. On his return, it is possible that the young artist took a route further to the west and passed through Cologne before reaching the southern Netherlands, enabling him to observe the art of the Flemish Primitives at first hand.

The style he forged over the course of his travels exhibits a fine balance between the naturalism of the Flemish masters and the idealised softness of painting in the Upper Rhine in the first half of the 15<sup>th</sup> century.



Martin Schongauer, Retable d’Orlier, *L’Annonciation*, 1470-1475, huile sur bois (sapin), Musée Unterlinden, Colmar



Martin Schongauer et son entourage, Retable des Dominicains, *La Présentation*, autour de 1480, peinture à l’huile sur bois (sapin), Musée Unterlinden, Colmar

# The Isenheim Altarpiece

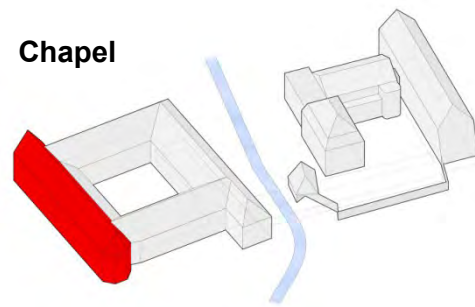

Between 1512 and 1516, the artists Niclaus of Haguenau (for the sculpted portion) and Grünewald (for the painted panels) created this celebrated altarpiece for the Antonite order's monastic complex at Isenheim, a village about 15 miles south of Colmar. This polyptych, which decorated the high altar of the monastery hospital's chapel until the French Revolution, was commissioned by Guy Guers, who served as the institution's preceptor from 1490 to 1516.

Established around 1300, the Isenheim monastery belonged to Saint Anthony's order, which had been founded in the Dauphiné region of France in the 11th century. The monks of the Antonite order ministered to victims of Saint Anthony's fire, a horrible illness that was common in the Middle Ages. This calamity's cause is now known to be poisoning from a fungus (ergot) that grows on rye grass, thus contaminating the rye flour used in making bread. Ergot contains a chemical that drives its victims mad and results in gangrene of the hands and feet due to constriction in blood flow to the extremities. To care for the sick, the Antonites served them good quality bread and had them drink a concoction called *saint vinage*, a holy fortified wine, in which the monks had first macerated a special blend of herbs and then soaked the relics of Saint Anthony. They also produced a salve from herbs possessing anti-inflammatory properties.

Little by little, the monks at Isenheim acquired a rich collection of works of art commissioned and financed by the monastery, one of which was this altarpiece. Held at this religious institution until the Revolution, it was transferred to the local branch of the French national library in 1792 for safekeeping. In 1852 it was moved to the chapel of the former Dominican convent known as the Unterlinden in Colmar, becoming the principal treasure of the museum being established at that time and has never ceased to captivate and enthral visitors since.

## • Isenheim Altarpiece - First view Wings closed

With the exception of certain holy days, the wings of the altarpiece were kept closed, displaying The Crucifixion framed on the left by the martyrdom of Saint Sebastian pierced by arrows, and on the right by Saint Anthony, remaining placid although he is being taunted by a frightening monster. The two saints protect and heal the sick, Saint Anthony as the patron saint of the victims of Saint Anthony's fire and

Saint Sebastian, whose aid was invoked to ward off the plague. Grünewald's Crucifixion stands as one of the most poignant representations of this scene in Western art due to the artist's masterful depiction of horrific agony, with Christ's emaciated body writhing under the pain of the nails driven through his hands and feet. This body covered with sores and riddled with thorns must have terrified the sick, but also left no doubt about Christ's suffering, thus comforting them in their communion with the Saviour, whose pain they shared. Mary, the mother of Jesus, is shown at Christ's right, collapsing in anguish in the arms of John, the beloved disciple of Christ, and shrouded in a large piece of white cloth. At Christ's left, John the Baptist is accompanied by a lamb, symbolising the sacrifice of Jesus. The presence of John the Baptist is anachronistic. Beheaded by order of Herod in 29 AD, he could not possibly have witnessed the death of Christ. This last figure announces the New Testament by crying out, "He must increase, but I must decrease." The inclusion of John the Baptist in this scene is symbolic, since he is considered as the last of the prophets to announce the coming of the Messiah.

## • Isenheim Altarpiece - Second view Outer wings opened

The outer wings of the Isenheim Altarpiece were opened for important festivals of the

liturgical year, particular those in honour of the Virgin Mary.

Thus are revealed four scenes: the left wing represents the Annunciation during which the archangel Gabriel comes to announce to Mary that she will give birth to Jesus, the son of God. The Virgin Mary is depicted in a chapel to indicate the sacred character of the event. In the central corpus, the Concert of Angels and the Nativity are not independent scenes but instead fit within a unified concept: the viewer witnesses Christ's coming to earth as a newborn baby, who will be led to combat the forces of evil personified by certain of the angels, disturbing in their physical appearance. A number of symbols provide keys to aid in interpretation: the enclosed garden represents Mary's womb and is a sign of her perpetual virginity, the rose bush without thorns refers to her as free of original sin, the fig tree symbolises mother's milk. The bed, the bucket and the chamber pot underscore the human nature of Christ. Lastly, the right wing shows the Resurrection, in which Christ emerges from the tomb and ascends into Heaven bathed in light transfiguring the countenance of the Crucified into the face of God. The Resurrection and the Ascension are therefore encapsulated in a single image.

- **Isenheim Altarpiece - Third view  
Inner wings opened**

**Saint Augustine and Guy Guers, Saint Anthony, Two Bearers of Offerings, Saint Jerome, Christ and the Twelve Apostles**

With its inner wings open, the Altarpiece allowed pilgrims and the afflicted to venerate Saint Anthony, protector and healer of Saint Anthony's fire. Saint Anthony occupies the place of honour at the centre of the corpus and at his side a pig is depicted, the emblem of the Antonite order. On his left and right, two bearers of offerings illustrate these contributions in kind, an important source of income for the Antonites. This central section is framed by Saint Augustine and Saint Jerome, two of the four great fathers of the Latin Church. Guy Guers, who had commissioned the Altarpiece, is depicted kneeling at the feet of Saint Augustine.

**Visit of Saint Anthony to Saint Paul the Hermit**

The two hermits meet in a stunning landscape, intended to represent the Theban Desert. Grünewald created a fantastic universe, surrounding the date palm with a strange mixture of vegetation, in marked contrast with the calmness and tranquillity of the encounter, in which the animals in attendance take part, with the crow bringing two morsels of bread to the two recluses. In this dreamlike scene, medicinal plants, painted in naturalistic fashion, sprout at the feet of the two main figures.

**Saint Anthony Tormented by Demons**

This panel depicts Saint Anthony being tormented by monstrous creatures sent by Satan. Trampled to the ground, beaten with sticks, torn by claws and bitten, Saint Anthony appeals to God for help who sends angels to combat these evil demons. In the lower left corner, the being with webbed feet and a distended belly seems to personify the disease caused by ergot poisoning, resulting in swelling and ulcerous growths.



*Vue du Retable d'Isenheim, chapelle du Musée Unterlinden Photo : Ruedi Walti*





Grünewald, *Retable d'Issenheim, L'Agresion de Saint Antoine par les démons*, détail, 1512-1516, Musée Unterlinden, Colmar



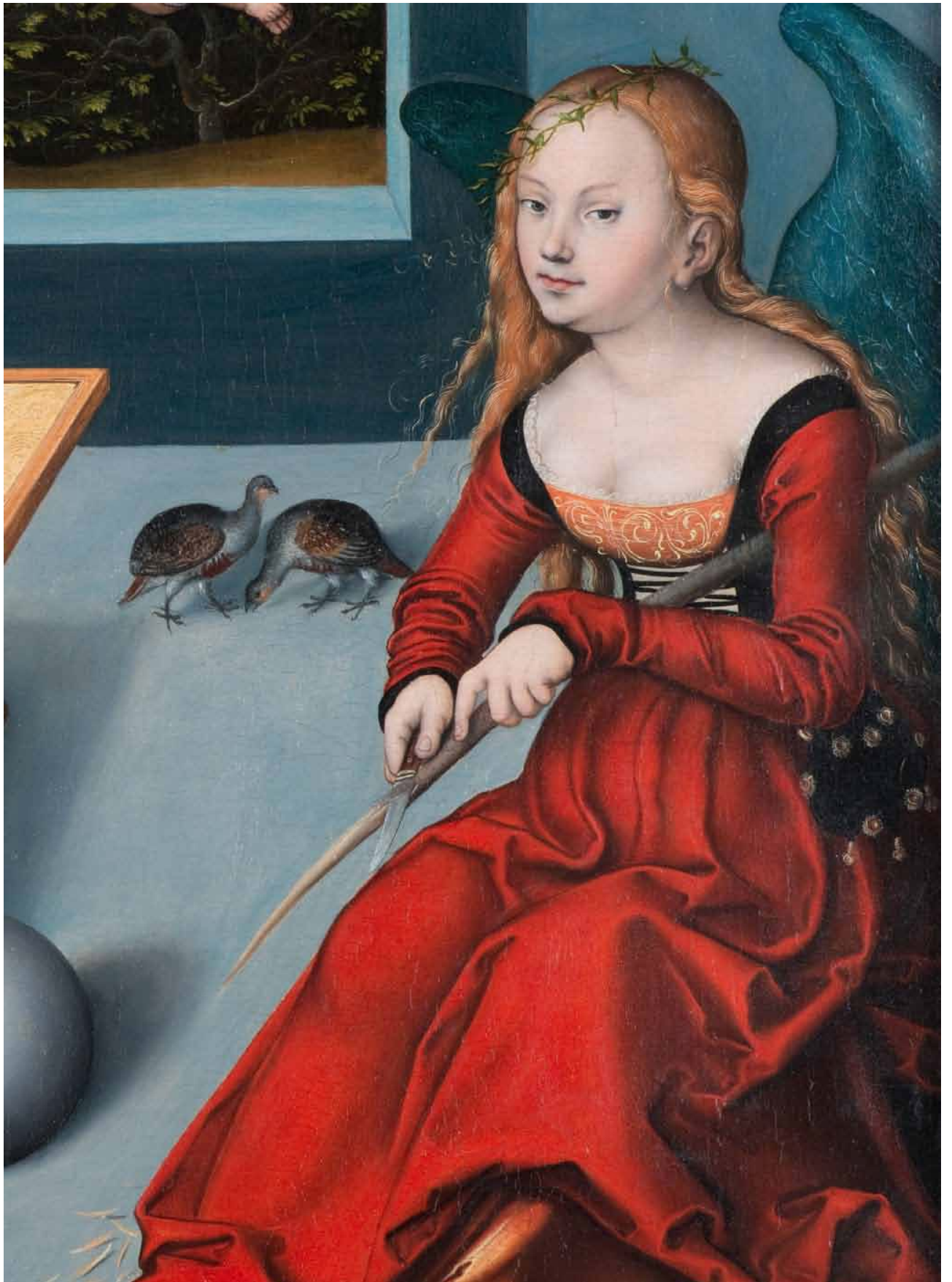

Lucas Cranach l'Ancien, *La Mélancolie*, détail, 1532, huile sur bois, Musée Unterlinden, Colmar



## **Decorative arts And Folk art and traditions**

Among the museum's decorative art holdings on view in this section are an exceptional group of objects in faience and porcelain produced in eastern France, treasures in silver and gold as well as remarkable hunting and military weapons. The museum's collection of folk art and traditions presents the Alsatian way of life, including its culinary traditions and the art of winemaking in Colmar, the wine capital of Alsace, with a wine cellar and wine presses.



# Archeological artifacts

Visitors exploring the museum's collection of archaeological artefacts learn about the various phases of human evolution through objects used in everyday life or for funerary rites. Among the most important pieces exhibited are an exceptionally rare iron dagger, a torque and a remarkable bracelet in gold that had belonged to a Celtic prince, and a Romanera mosaic.



Vases, vers 5500 av. J.C., céramique, Musée Unterlinden, Colmar



Mosaïque de Bergheim, 3e siècle, pierre, Musée Unterlinden, Colmar



Les bijoux en or d'une sépulture princière, datée des environs de 500-480 avant J.-C., Ensisheim, Musée Unterlinden, Colmar

## Gallery

This gallery connecting the former convent to the new structure is divided into three exhibition spaces presenting the museum's history as well as its collections of art from the nineteenth and early twentieth centuries.

## House

A focal point of the new Musée Unterlinden, the Petite Maison brings natural light into the underground gallery and presents three emblematic works: Théophile Schuler's *Chariot of Death* (1851), engaging with history and the past, Georges Rouault's *The Child Jesus Among the Doctors* (1894), attesting to the extent of the museum's holdings in religious art, and Nicolas de Staël's *Portrait of Anne* (1953), indicating its openness to modern and contemporary art.

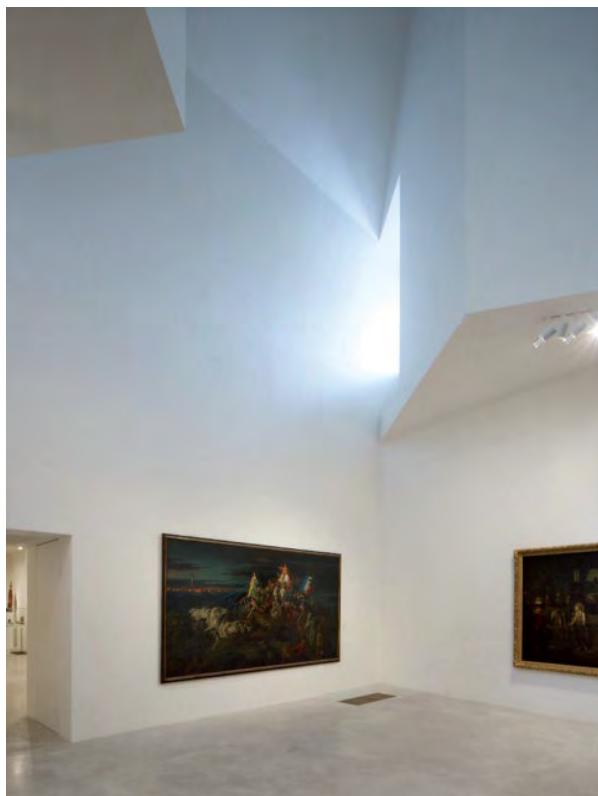

Vue intérieure de la Maison, Musée Unterlinden, Colmar

## Gallery

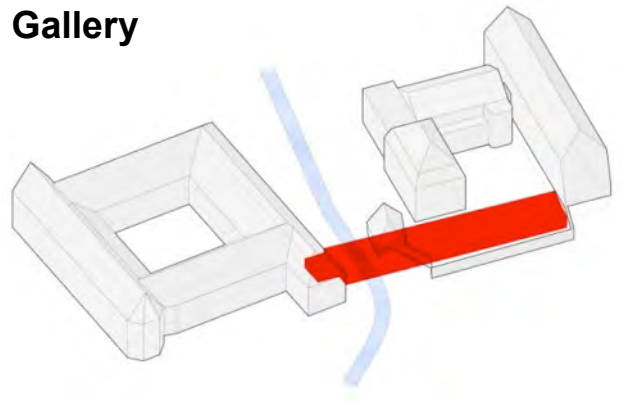

Claude Monet, *La Vallée de la Creuse, soleil couchant*, 1889, huile sur toile, Musée Unterlinden, Colmar



Henri Lebert, *Vue du Haut-Landsbourg*, 1833, huile sur toile



## L'Ackerhof : The new wing

The two levels of the museum's new wing, sheathed in copper with a textured façade composed of broken bricks, house its modern art collection.

Works of major artists such as Dubuffet and Picasso are presented here. The collection is especially strong in artists representing movements in abstract art after the Second World War (Poliakoff, Soulages, Vieira da Silva).

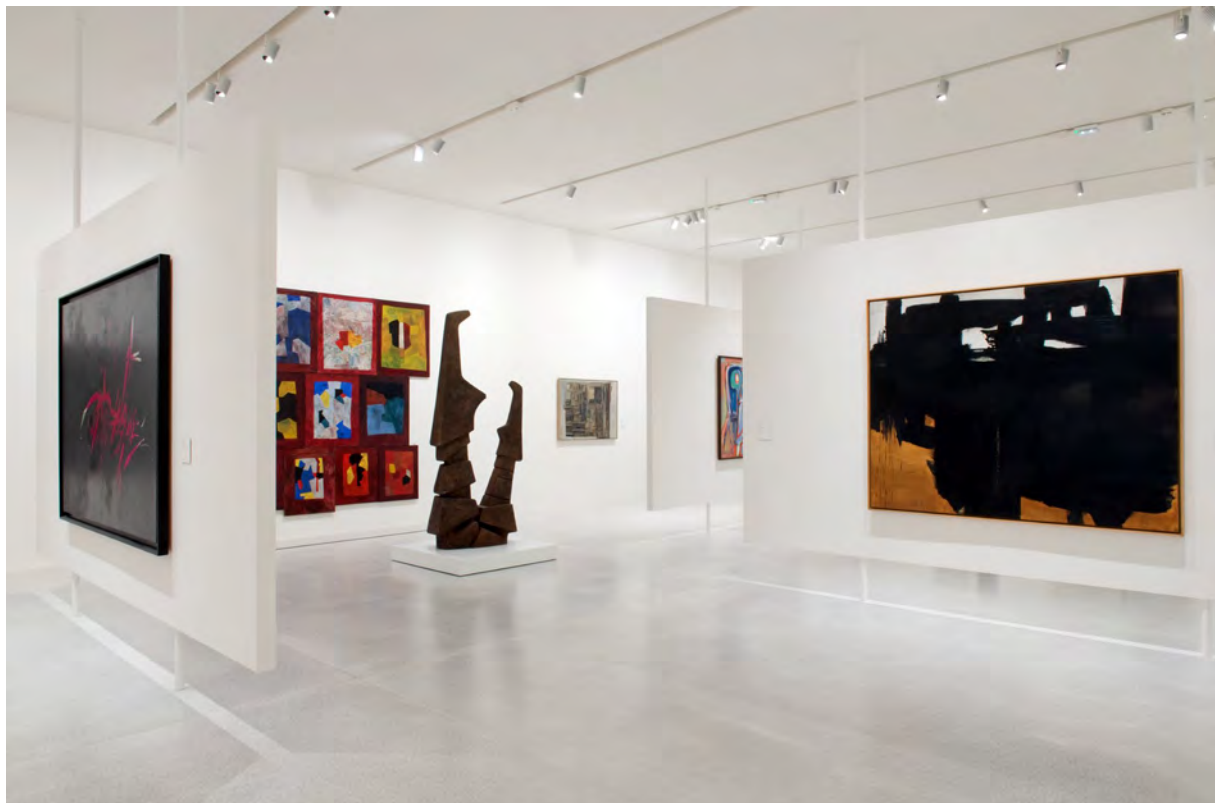
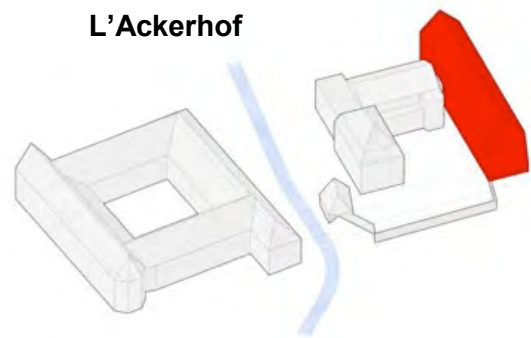

*Vue de la salle d'art moderne, 1<sup>er</sup> étage, Ackerhof © Herzog & de Meuron*



Jacqueline de La Baume, *Guernica* (d'après l'œuvre de 1937 de Pablo Picasso), 1976, tapisserie en basse-lisse, Musée Unterlinden, Colmar

## Guernica

Jacqueline de La Baume-Dürnbach trained in Paris with a master artisan from Aubusson. She was important for her transpositions of works by the great Cubist masters into tapestry. In 1951 her exhibition at the Musée de l'Annonciade in Saint-Tropez was seen by Picasso, and this was the beginning of a rich collaboration between the two artists. Her great strength as a tapestry-maker was her ability to faithfully recapture the spirit of the artist's work while bringing a new dimension to the harmony of rhythms and colours that structured the original painting. Between 1954 and 1984, forty-seven tapestries were made in her studio, twenty-seven of them inspired by Picasso's works.

Impressed by La Baume-Dürnbach's ability to reproduce his work without copying it, Picasso suggested to the collector Nelson A. Rockefeller that he commission a tapestry after his masterpiece *Guernica* (1937). The contract was signed in 1955, with the stipulation that the work be supervised by Picasso, who authorised an edition of three. In June 1955, when Picasso's original painting *Guernica* was exhibited at the Musée des Arts Décoratifs in Paris, La Baume-Dürnbach studied the work and conceived the cartoon for her tapestry.

Picasso then gave the go-ahead for the making of the tapestry.

Acquired by Nelson A. Rockefeller, this first copy of *Guernica* was placed at the UN in New

York, where it has been hung at the entrance to the Security Council Chamber since 1985.

Made at Saint-Rémy-de-Provence in 1976, the second version of *Guernica* was presented the following year in an exhibition of tapestries from the Dürnbach studio in Paris, and then at the Musée Unterlinden (1978), which purchased the work in 1979. The third copy of *Guernica* was executed in 1983 and acquired in 1996 by the Museum of Modern Art, Gunma, Takasaki, in Japan. The three tapestries comprise eleven shades of wool. The second and third copies have coloured edging, as requested by Picasso.





Jean Dubuffet, *Don Coucoubazar*, 1972, assemblage de tôle peinte au polyuréthane



Nicolas de Staël, *Portrait d'Anne*, 1953, huile sur toile

# La piscine

With the renovation of the municipal baths, this edifice is returned to its early twentieth-century glory. Special events organised by the Musée Unterlinden are held at this venue (exhibitions, concerts, conferences, etc.), which may also be reserved for private receptions.

## La piscine

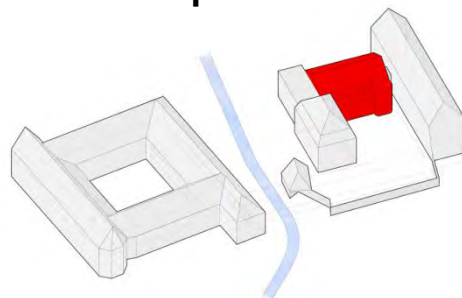

*Vue de la salle événementielle, la Piscine* Photo : Peter Mikolas

# Annexes

---

## **Jacques Herzog, Senior Partner, Herzog & de Meuron :**

"The interplay between city planning, architecture and museography renders the Unterlinden project most exceptional: one leads to the other. From the angle of urban development, the most decisive contribution is the enhancement of the formerly desolate zone between the cloister and the former public Baths. Then, the opening of the formerly covered canal provides an attractive site for Colmar: it is here that the entrance to the new museum complex has been transferred. And still another exceptional aspect: only close scrutiny distinguishes the old from the new architecture of the complex's various parts."

## **Pierre de Meuron, Senior Partner, Herzog & de Meuron :**

"The Unterlinden Museum is a truly international institution. On the one hand, its collection—together with, in particular, the Isenheim Altar— is an integral and central part of the cultural heritage of France on the periphery of which the museum is situated. On the other hand, the collection represents a core part of Europe's cultural heritage as a whole, while also serving as an invaluable manifesto thereof. It is our hope that the Unterlinden Museum will come to be seen as an institution standing for the history of Europe, and this above and beyond any national boundaries."

## **Christine Binswanger, Senior Partner, Herzog & de Meuron :**

"Visitors will experience the expanded Unterlinden Museum as an organic, complex sequence of inside and outside spaces. In our profession, only rarely do we have the occasion to custom tailor architecture to such a degree, to a content that spans several centuries. We had a chance to simultaneously, and equally intensively, address changes to the urban fabric as well as the presentation of a single work of art."

# Informations

## Musée Unterlinden

Place Unterlinden – 68000 Colmar

Tel. +33 (0)3 89 20 15 50

info@musee-unterlinden.com

www.musee-unterlinden.com

## Presse

Marie-Hélène Siberlin

Responsable de la communication

Musée Unterlinden + 33 (0)3 89 20 22 74 - mhsiberlin@musee-unterlinden.com

## Gestionnaire du musée

### Société Schongauer

Place Unterlinden F-68000 Colmar

## Président

Thierry Cahn

## Musée Unterlinden

Camille Broucke

Directrice - Conservatrice du patrimoine - Chargée de l'art ancien

Françoise Schmitt

Administrateur

Raphaël Mariani

Conservateur du patrimoine - Chargé des Arts décoratifs, d'ethnologie et du 19e siècle

Magali Haas

Documentaliste scientifique - Chargée de la collection d'arts graphiques

## Admission fees

**13 €**

**11 €** Groups of 15 or more persons, senior citizens

**8 €** Youths 12-18 and Students (under 30)

**6,50 €** Last hour price

**Free:** children under 12

## Opening time

Monday 9–18 h

Tuesday closed

Wednesday – Sunday 9–18 h

## Special opening:

24.12, 31.12: 9–16h

1.1, 1.5, 1.11, 25.12 closed

## Public transport

Train Station in Colmar: Regional train; departure all 30 min. From the train station to the museum by foot: 15 min

Bus from the train station to the museum: Lines 1, 3, 4, 5, 7, 8; Théâtre stop

By car: Follow signs for the Mairie, Lacarre and Scheurer-Kestner parking garages in the city centre

Airports: Euroairport Basel-Mulhouse- Freiburg / Strasbourg